

# EUROPA

Porta ad un'anta a battente PIVOT

**B7855 - B7856 - B7857**  
**7858 - B7859**

Istruzioni di Montaggio

Assembly instruction

Instructions de montage

Montageanleitung

Instrucciones de montaje

Instruções de montagem

  
lineabeta

## AVVERTENZE E SUGGERIMENTI PER UNA CORRETTA INSTALLAZIONE, USO E MANUTENZIONE DEL BOX DOCCIA

### AVVERTENZE PRIMA DELL'INSTALLAZIONE:

- 1) Prima di procedere a qualsiasi operazione di installazione. verificare la corrispondenza del box ordinato con quello consegnato e verificare l'integrità di tutti i suoi componenti.
- 2) In particolare modo per i prodotti che hanno lastre prive di profili/telaio e assolutamente necessario mantenere le protezioni esistenti fino alla fine dell'installazione per evitare di appoggiare/sbattere le lastre determinando possibili rotture/scoppi anche successivi all'installazione.
- 3) Prima di eseguire qualsiasi operazione di foratura è necessario accertarsi che la dimensione del box corrisponda a quella del piatto.
- 4) E' necessario accertarsi che il muro non abbia un eccessivo fuori squadra. in quanto potrebbe rendere scarsa l'estensibilità del box compromettendone in certi casi la funzionalità stessa.
- 5) I box senza telaio devono essere installati sul bordo interno del piatto, per permettere l'alloggiamento del frangiflutto.
- 6) Per l'installatore: seguire attentamente le istruzioni allegate.
- 7) Nel caso di reso autorizzato. il prodotto dovrà essere re-imballato mantenendo le stesse caratteristiche di integrità che aveva nel momento della consegna.

Per qualsiasi inconveniente contattare il rivenditore.

### USO E MANUTENZIONE:

- 1) Per la pulizia periodica di tutte le superfici del box doccia e in particolare per tutte le parti in alluminio e in plastica, si consiglia di usare acqua e normali detergenti liquidi delicati per la pulizia della casa con l'utilizzo di una spugna o un panno morbido, e di non usare assolutamente prodotti aggressivi, disincrostanti o abrasivi.
- 2) Per mantenere nel tempo una buona funzionalità del prodotto, è necessario periodicamente fare una manutenzione generale e in particolare regolare e lubrificare le parti in movimento.

---

## WARNINGS AND SUGGESTIONS FOR A CORRECT SHOWER ENCLOSURE INSTALLATION, USE AND MAINTENANCE

### PRECAUTIONS BEFORE INSTALLATION:

- 1) Before proceeding to any assembling operation. please verify if the delivered shower enclosure exactly corresponds to the ordered one, verifying also the complete components integrity.
- 2) In particular it is strongly recommended that for the frame-less products it is absolutely necessary to keep the existing installed protections till the end of the product assembling avoiding to lean or to knock the glass panels that could determinate possible subsequent breakage or shatters even after the final installation.
- 3) Before performing any drilling operation. please verify that the shower enclosures measures correspond to the shower tray dimensions.
- 4) It is absolutely necessary to verify the eventual wall's out of square exceeding measure. otherwise it could compromise the projected shower enclosure extensibility (not sufficient) and in some case the relative functionality.
- 5) Frameless shower enclosures have to be installed on the shower tray internal edge, to allow the breakwater gasket housing.
- 6) For the fitter: please carefully follow the enclosed instructions.
- 7) In case of authorised product return all must be exactly re-packaged maintaining the same delivery integrity characteristics.

For any inconvenient please contact the local dealer.

### USE AND MAINTENANCE:

- 1) For the periodic shower enclosure cleaning surfaces and in particular the aluminium profiles and plastic components, absolutely do not use aggressive, abrasive or scale-remover products, but only use water and normal house cleaning liquid detergents with a sponge or a soft cloth.
- 2) To maintain a good shower enclosures functionality. it is necessary to periodically perform a general maintenance particularly regulating and lubricating the moving parts.

---

## AVERTISSEMENTS ET SUGGESTIONS POUR UNE INSTALLATION, UNE UTILISATION ET UN ENTRETIEN CORRECTS DE LA PAROI DE DOUCHE

### AVERTISSEMENTS AVANT INSTALLATION:

- 1) Avant de procéder à l'installation, vérifier la correspondance entre la paroi commandée et celle livrée et contrôler l'intégrité de tous ses composants.
- 2) En particulier pour les produits réalisés à partir de panneaux de verre sans profile ni cadre. il est absolument nécessaire de conserver les protections existantes jusqu'à la fin de l'installation pour éviter d'appuyer ou de frapper le verre provoquant de la sorte d'éventuels chocs ou bris de verre pouvant également intervenir une fois l'installation terminée.
- 3) Avant d'effectuer toute opération de perçage, il est nécessaire de vérifier que la dimension de la paroi corresponde à celle du receveur.
- 4) Il est nécessaire de vérifier que le mur ne présente pas un faux-aplomb exagéré, dans la mesure où cela pourrait rendre insuffisant la fourchette d'extensibilité de la paroi, compromettant dans certains cas son utilisation même.
- 5) Les parois sans cadre doivent être installées sur le bord intérieur du receveur, pour permettre le positionnement du joint brise-flux.
- 6) Pour l'installation suivre scrupuleusement les instructions de montage jointes.
- 7) En cas de retour autorisé, le produit devra être réemballé en respectant les mêmes caractéristiques d'intégrité qu'il possédait au moment de la livraison.

En cas de problème, contacter votre revendeur.

### UTILISATION ET ENTRETIEN:

- 1) Pour le nettoyage périodique de toutes les surfaces de la paroi de douche et en particulier toutes les parties en aluminium et plastique, il est conseillé d'utiliser de l'eau et des détergents liquides délicats pour le nettoyage de la maison, en utilisant une éponge ou un linge souple et de ne pas utiliser de produits agressifs, désincrostant ou abrasifs.
- 2) Pour maintenir dans le temps une bonne fonctionnalité du produit, il est indispensable de procéder périodiquement à un entretien général et en particulier régler et lubrifier les parties en mouvement.

---

## RATSCHLAGE FÜR EINE KORREKTE MONTAGE UND PFLEGE DER DUSCHKABINEN

### HINWEISE VOR DER MONTAGE:

- 1) Überzeugen Sie sich vor der Montage:  
Überprüfen den von Ihnen bestellten Artikel mit den gelieferten.  
Überprüfen die Integrität der einzelnen Komponenten
- 2) Bei rahmenlosen Produkten ist unbedingt die Kunststoffschutz bis am Ende der Montage auf den Scheiben zu lassen. Diese Maßnahme vermeidet mögliche Glasbrüche.
- 3) Bevor Sie die Löcher in die Mauer bohren, überprüfen Sie ob die Duschtrennung und die Duschwanne übereinstimmen.
- 4) Die Mauer sollte nicht mehr als 1,5 cm außer Lot sein.
- 5) Rahmenlose Duschkabinen müssen mit Anschlag der Innenkante von der Duschwanne montiert werden um somit den Schwelleiste zu montieren.
- 6) Bei Installation der Duschtrennung folgen die Montageanleitungen.
- 7) Bei berechtigter Rücksendungen. muß die Duschtrennung in der selbe Verpackungsart wie von dem Hersteller geschickt war, verpackt sein.

Bei eventuelle Schwierigkeiten, mit dem Fachhandel in Verbindung setzen.

### GEBRAUCH UND PFLEGE:

- 1) Für die periodische Reinigung aller Duschtrennung Oberfläche, besonders für die Kunststoff und Aluminium Teilen, ratet man nur Wasser und leichte Washmitteln mit Schwamm benutzen. Kein aggressive, abschleifende oder entzündende Waschmittel benutzen.
- 2) Um eine gute und lange Betrieb des Produktes zu gewähren ist nötig eine periodische allgemeine Pflege und auch die Schmierung der Schiebenelemente.



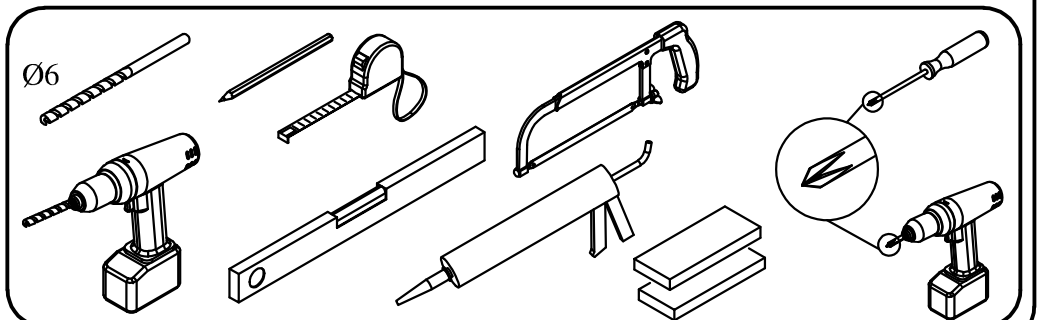
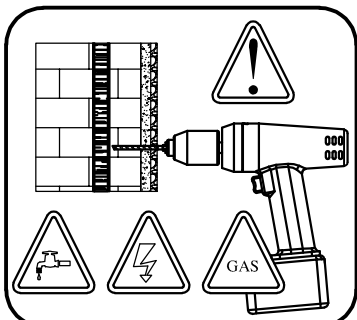
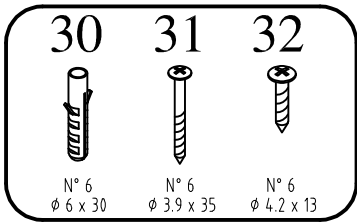
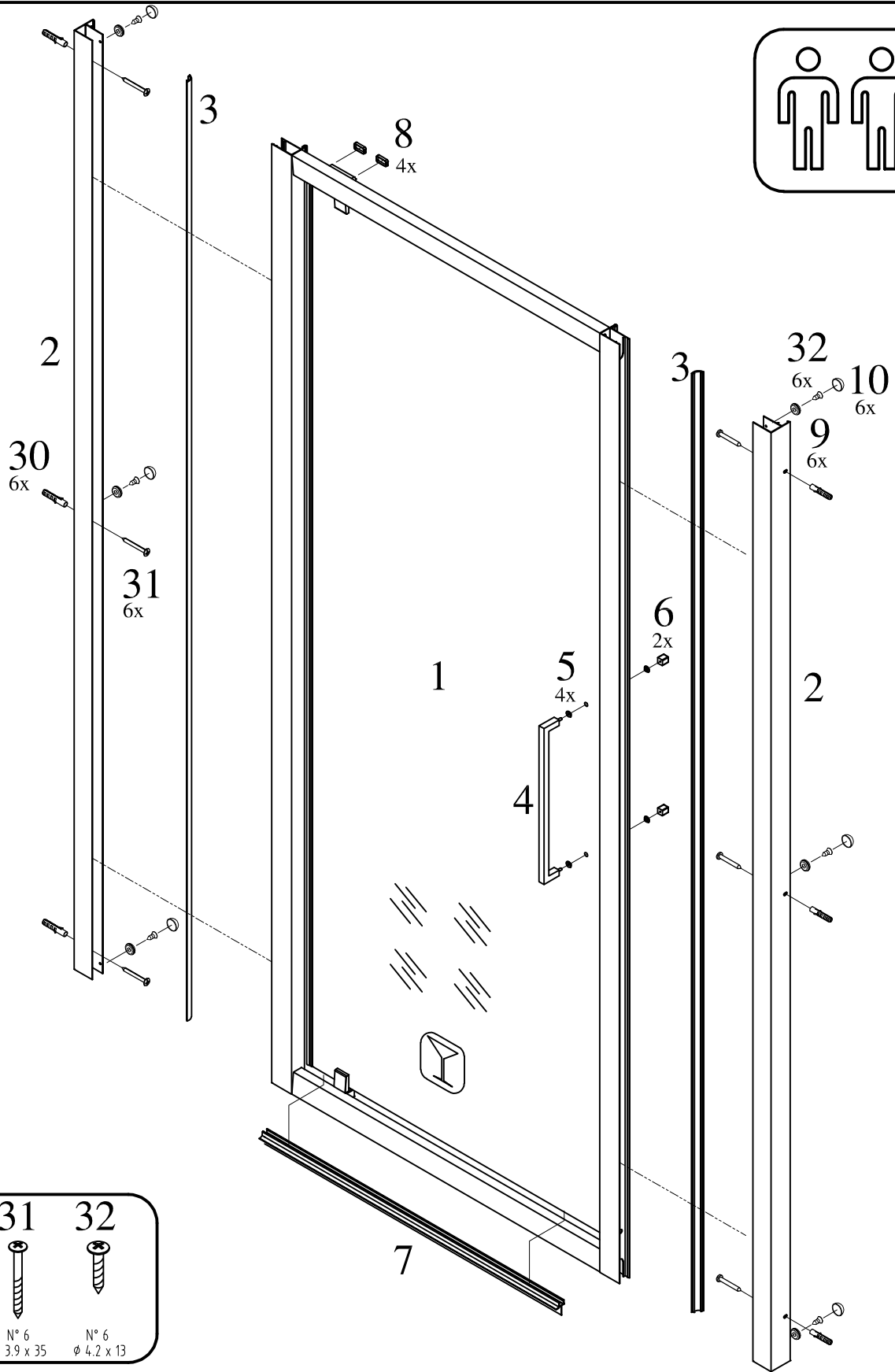
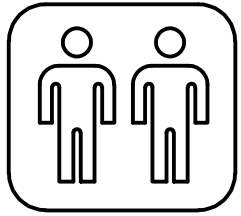

RIC1712\*\*\*

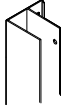

RIC1729\*\*\*

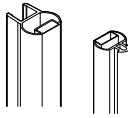

RIC1927\*\*\*

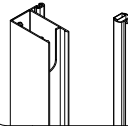

RIC1799



RIC3020\*\*\*



RIC...

RIC1727\*\*\*



RIC1723\*\*\*

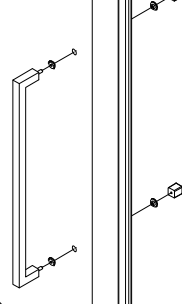

RIC1754\*\*\*

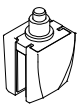

RIC3019\*\*\*

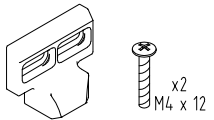

RIC...

RIC3018

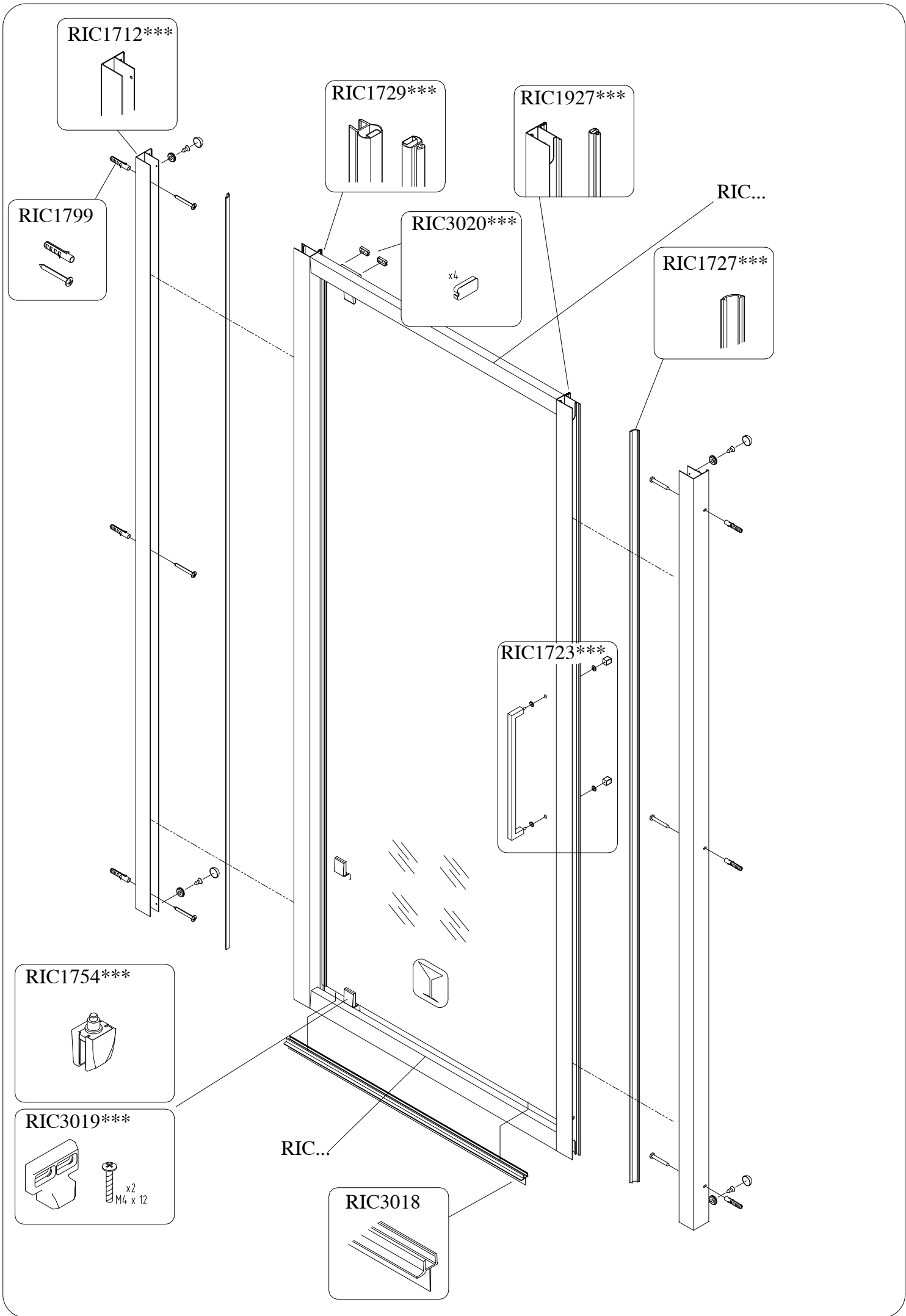
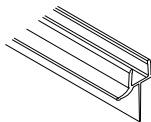

*RIC1712\*\*\**

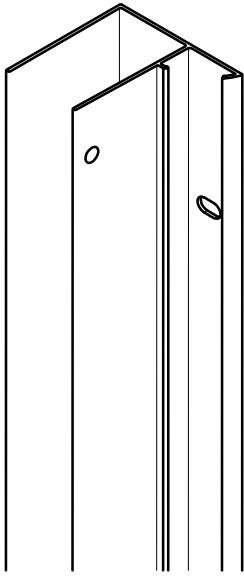

*RIC1723\*\*\**

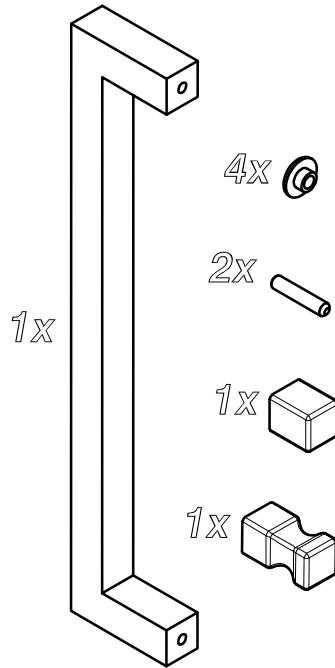

*RIC1729\*\*\**

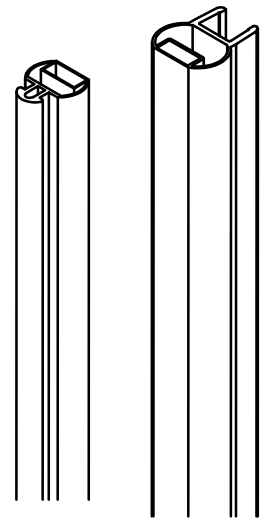

*RIC1727\*\*\**

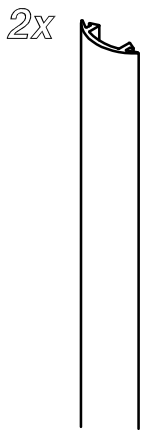

*RIC1927\*\*\**

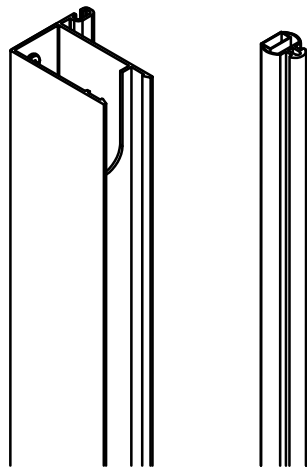

*RIC3019\*\*\**

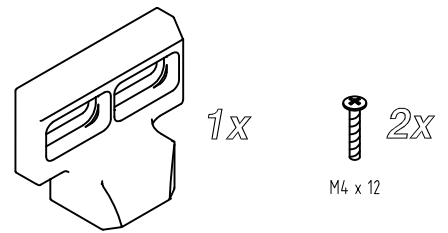

*RIC3020\*\*\**



*RIC3018*

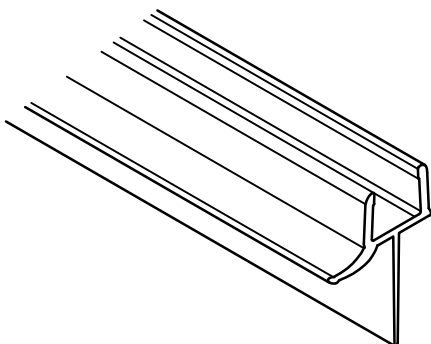

*RIC1799*

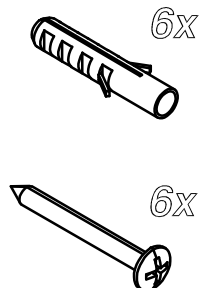

*RIC1754\*\*\**

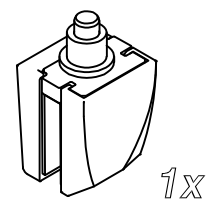

*RIC...*

B7855	558	RIC2783XXX
B7856	618	RIC2785XXX
B7857	678	RIC2787XXX
B7858	758	RIC2789XXX
B7859	858	RIC2791XXX

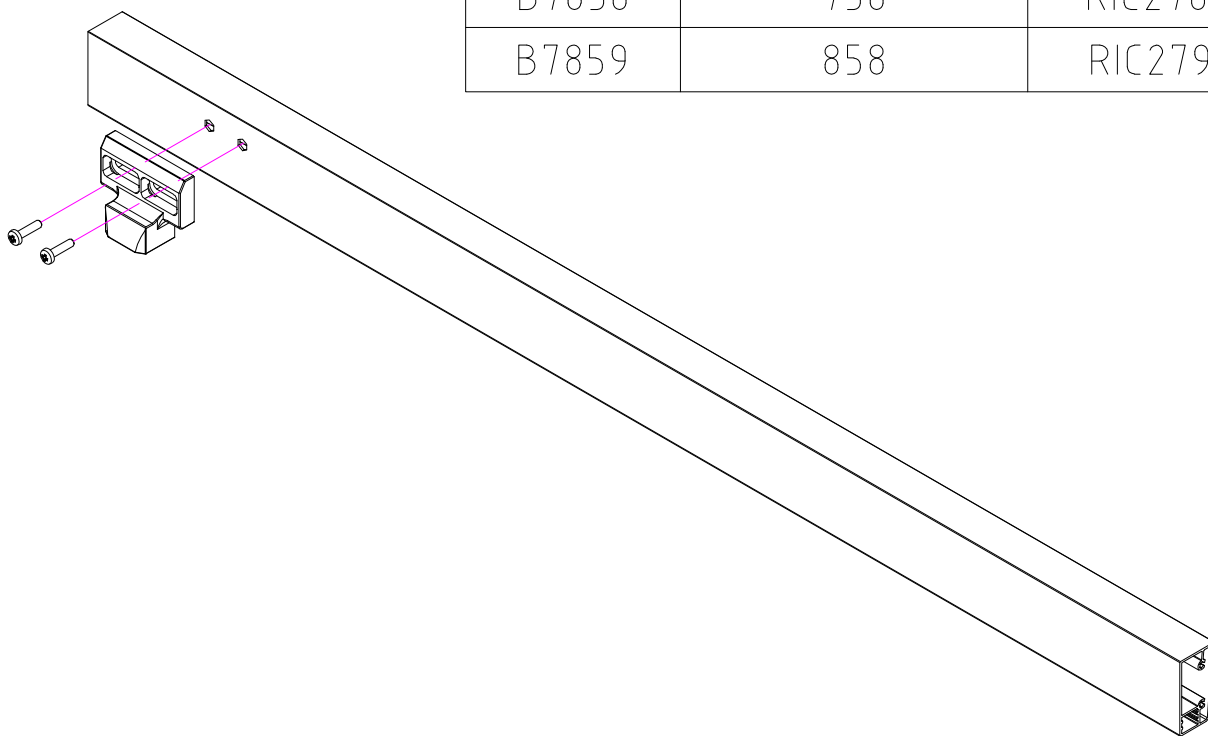

*RIC...*

B7855	558	RIC2784XXX
B7856	618	RIC2786XXX
B7857	678	RIC2788XXX
B7858	758	RIC2790XXX
B7859	858	RIC2792XXX

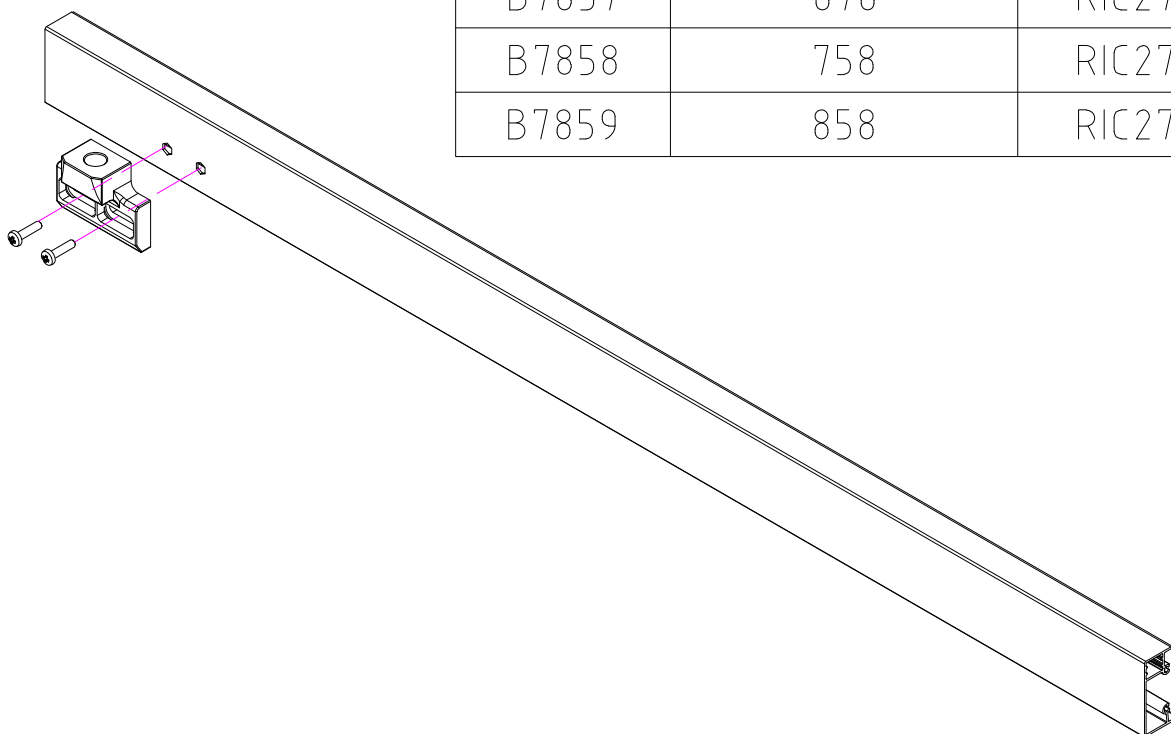

1

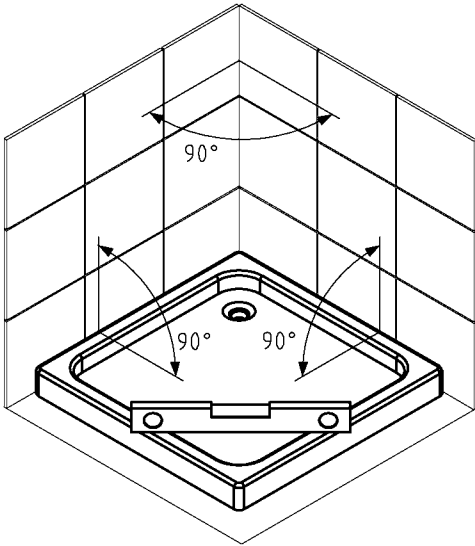

2

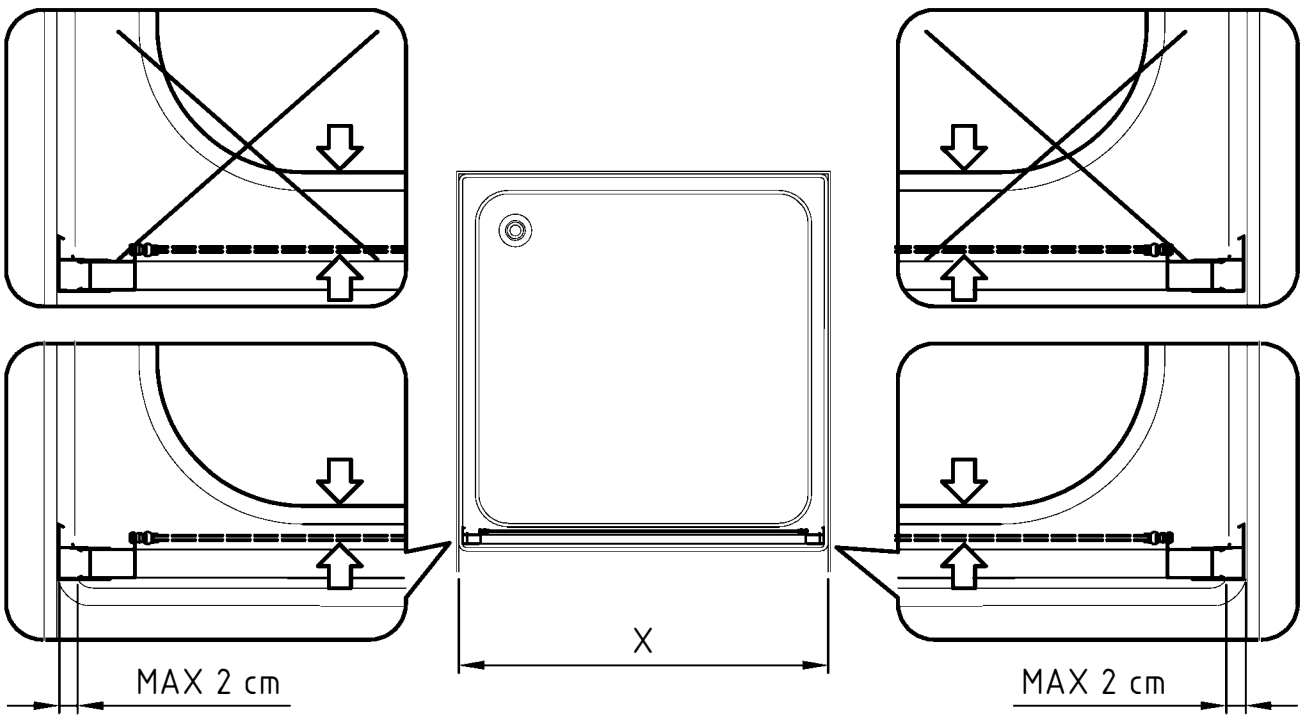

Model	X
B7855	66-72 cm
B7856	72-78 cm
B7857	78-84 cm
B7858	86-92 cm
B7859	96-102 cm



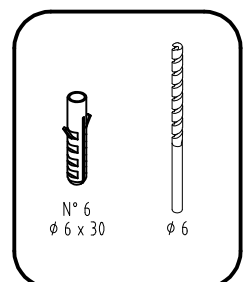
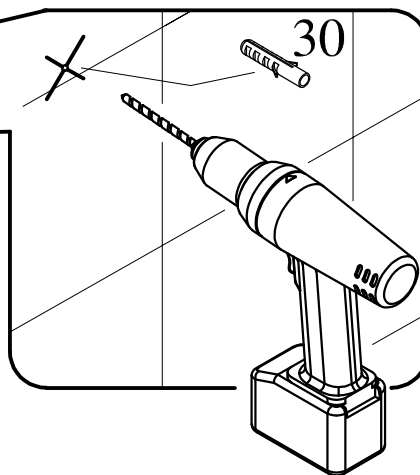
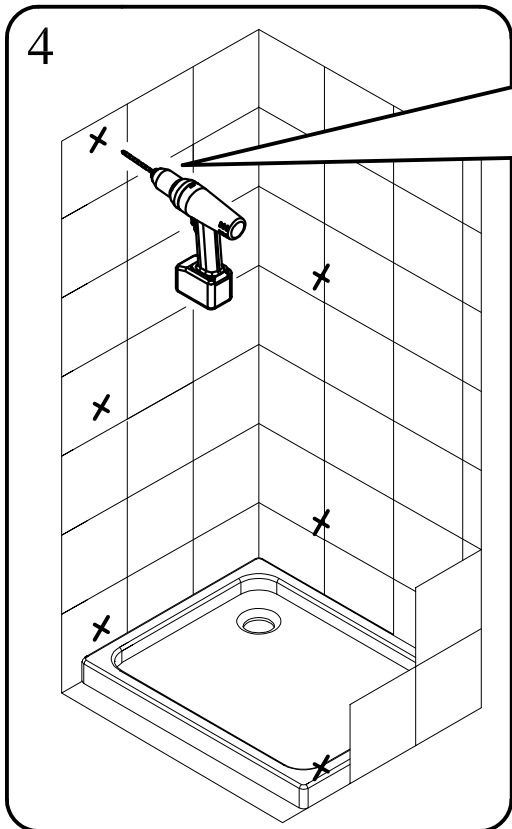
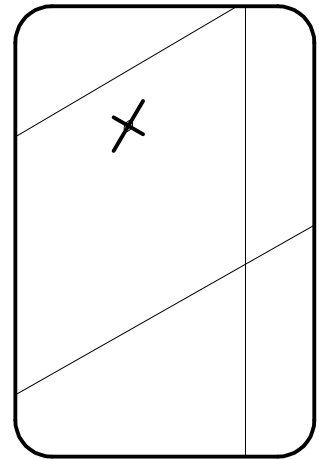
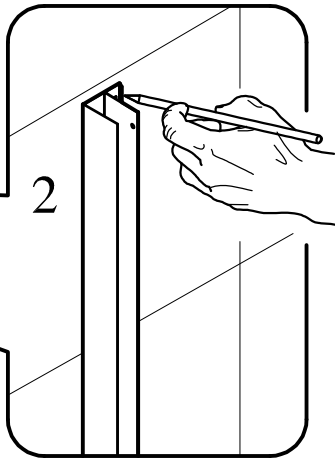
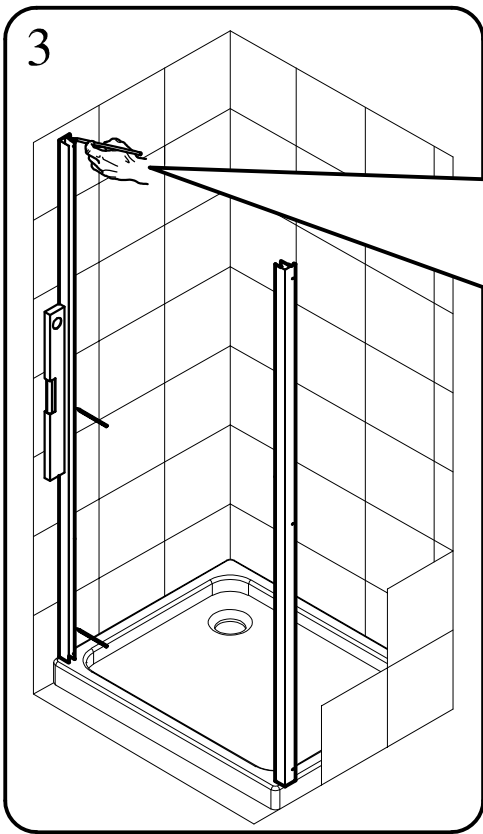

5

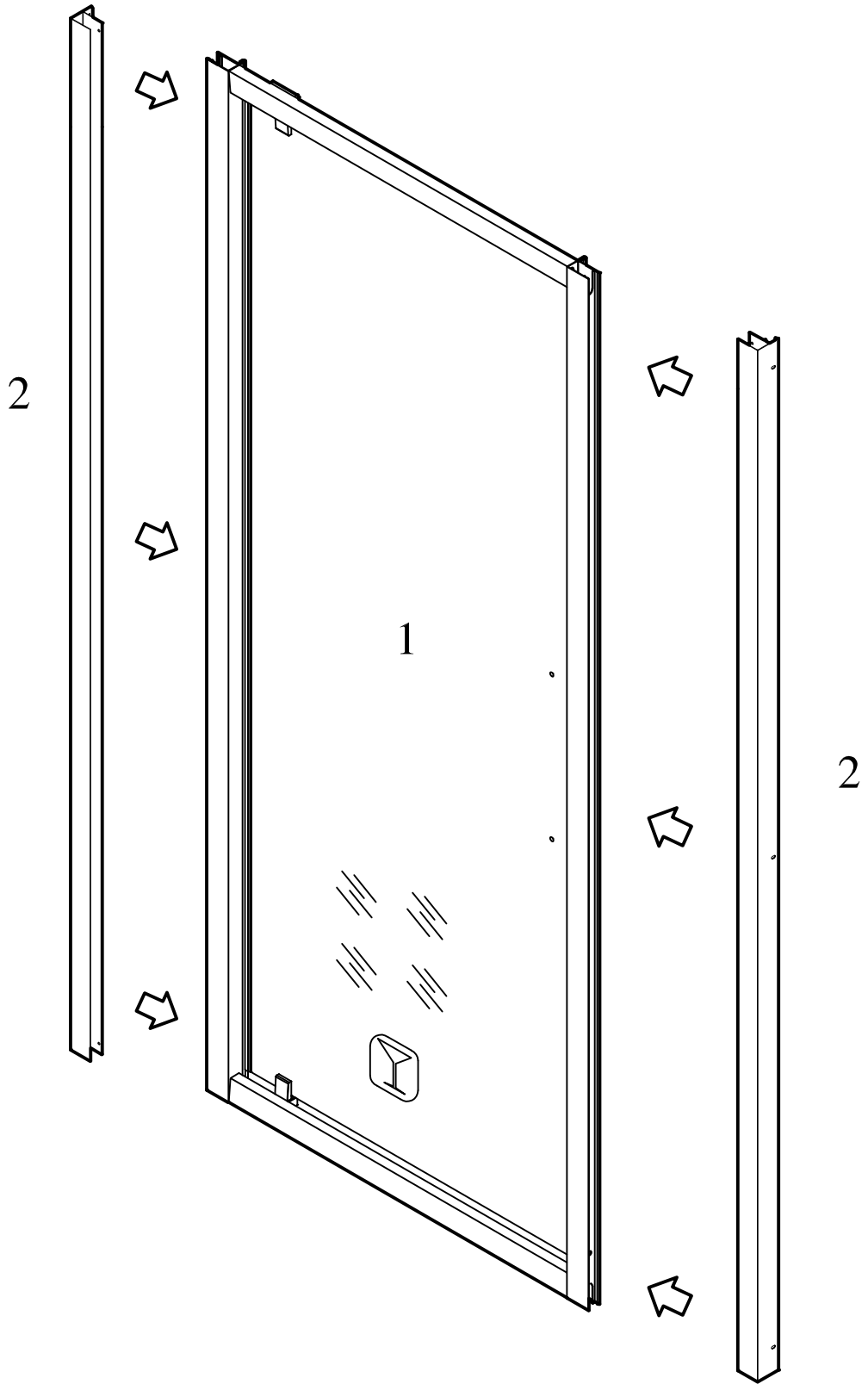

6

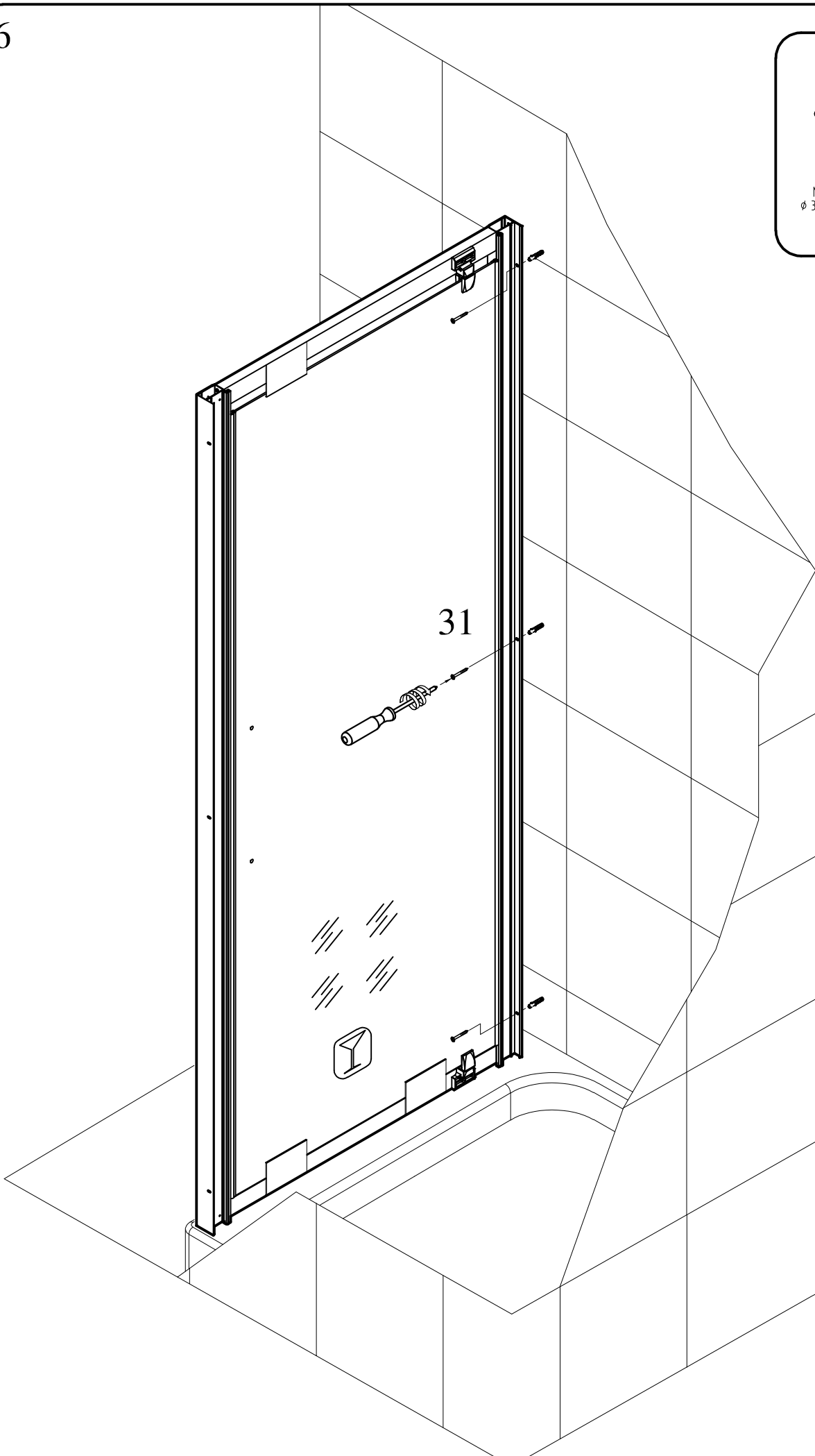
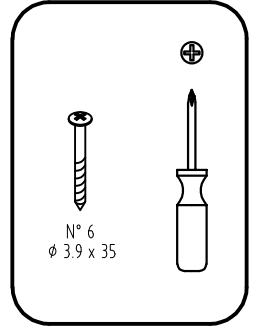

7

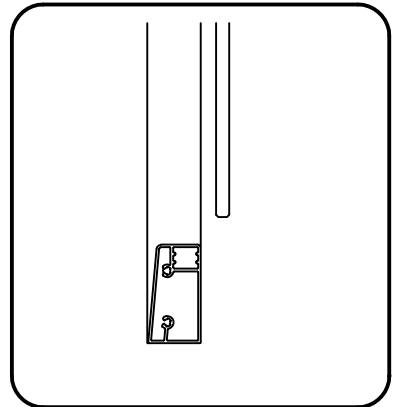
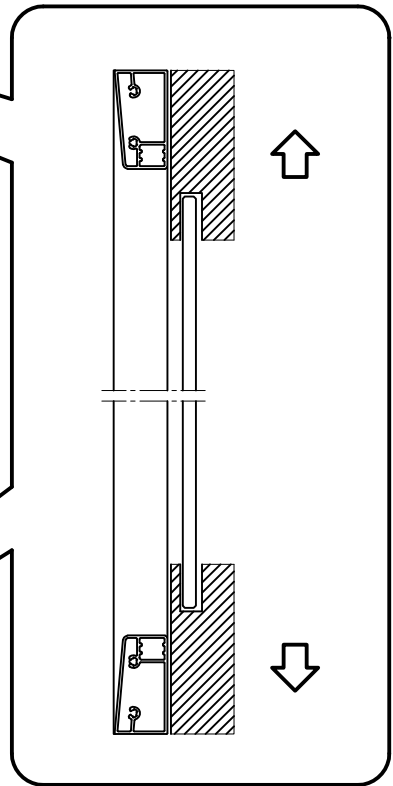
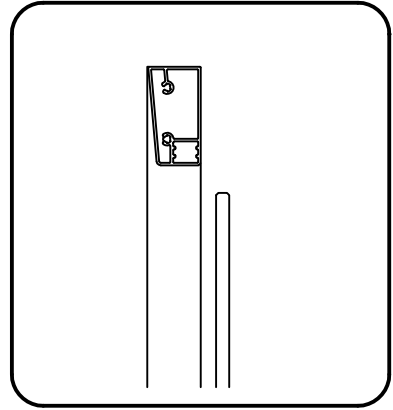
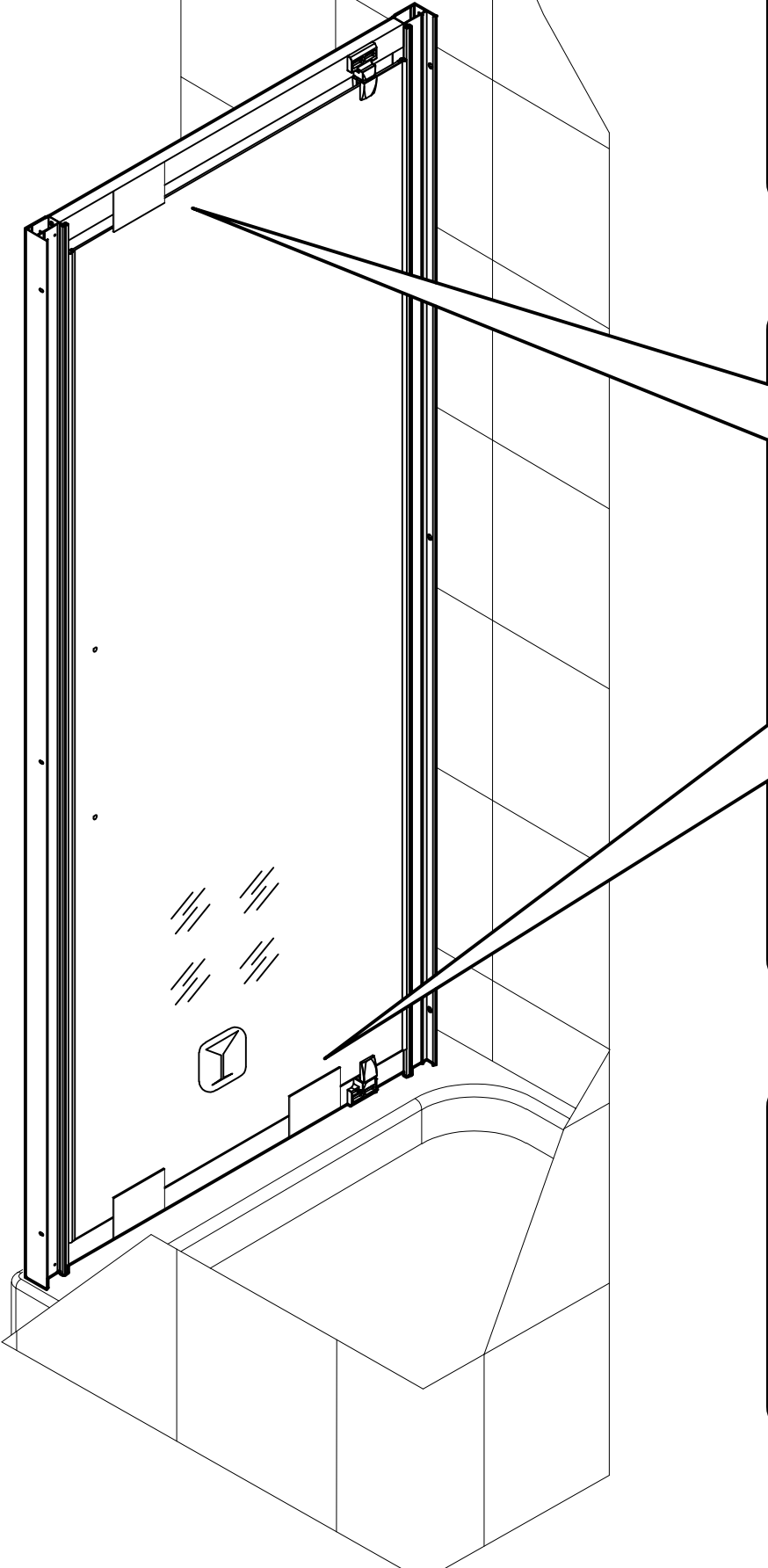

8

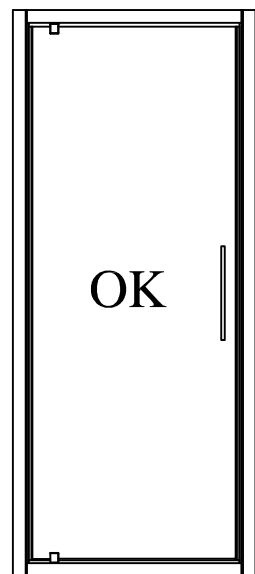
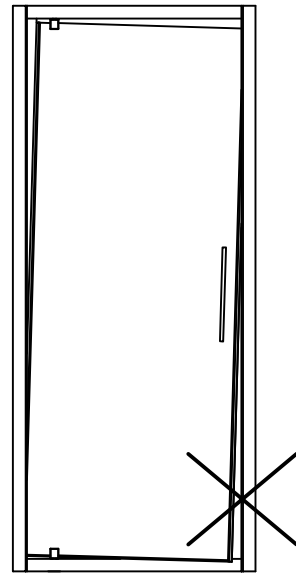
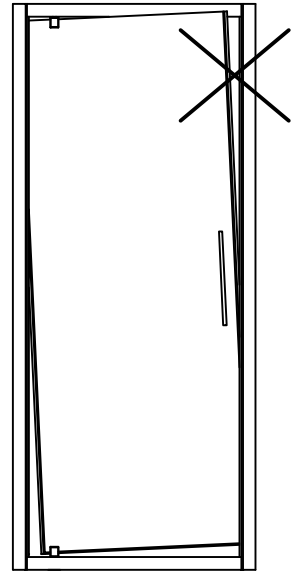
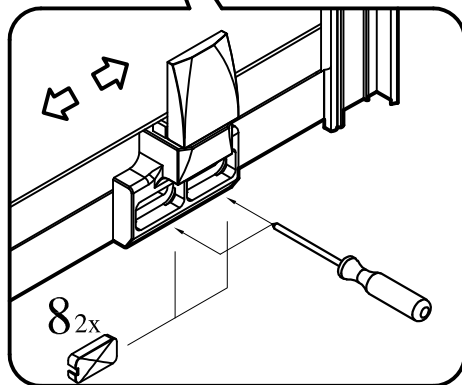
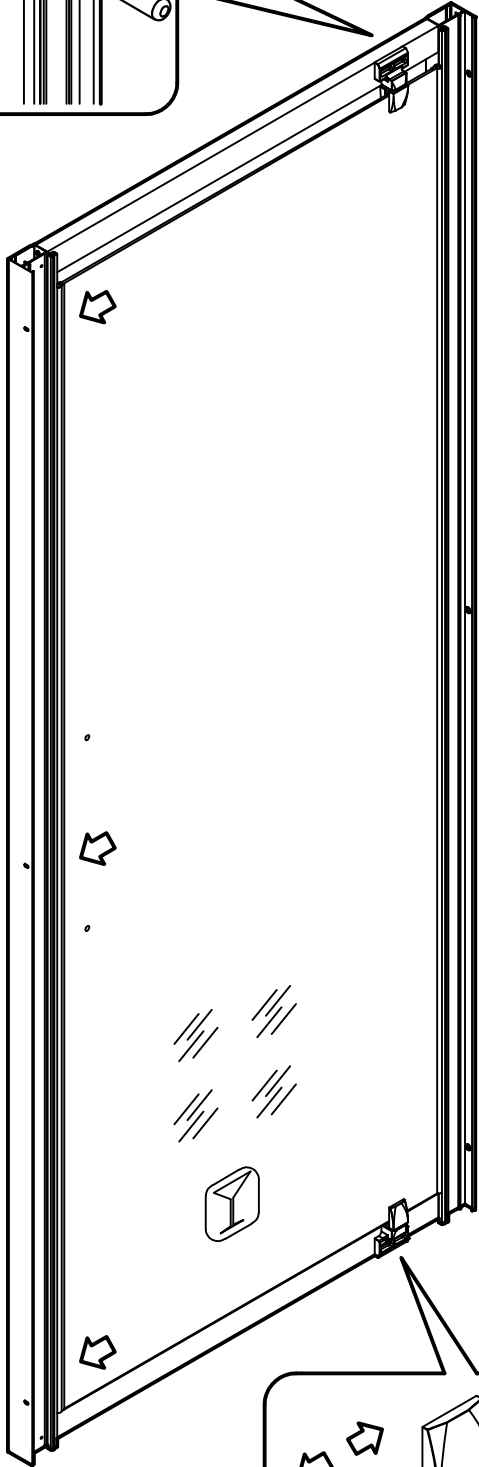
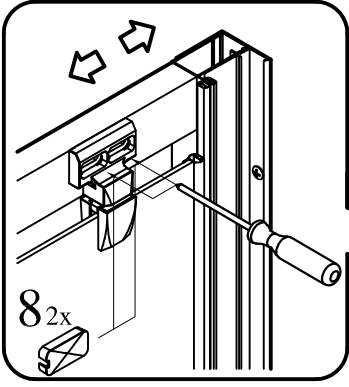

9

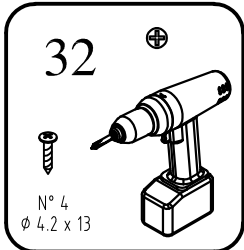
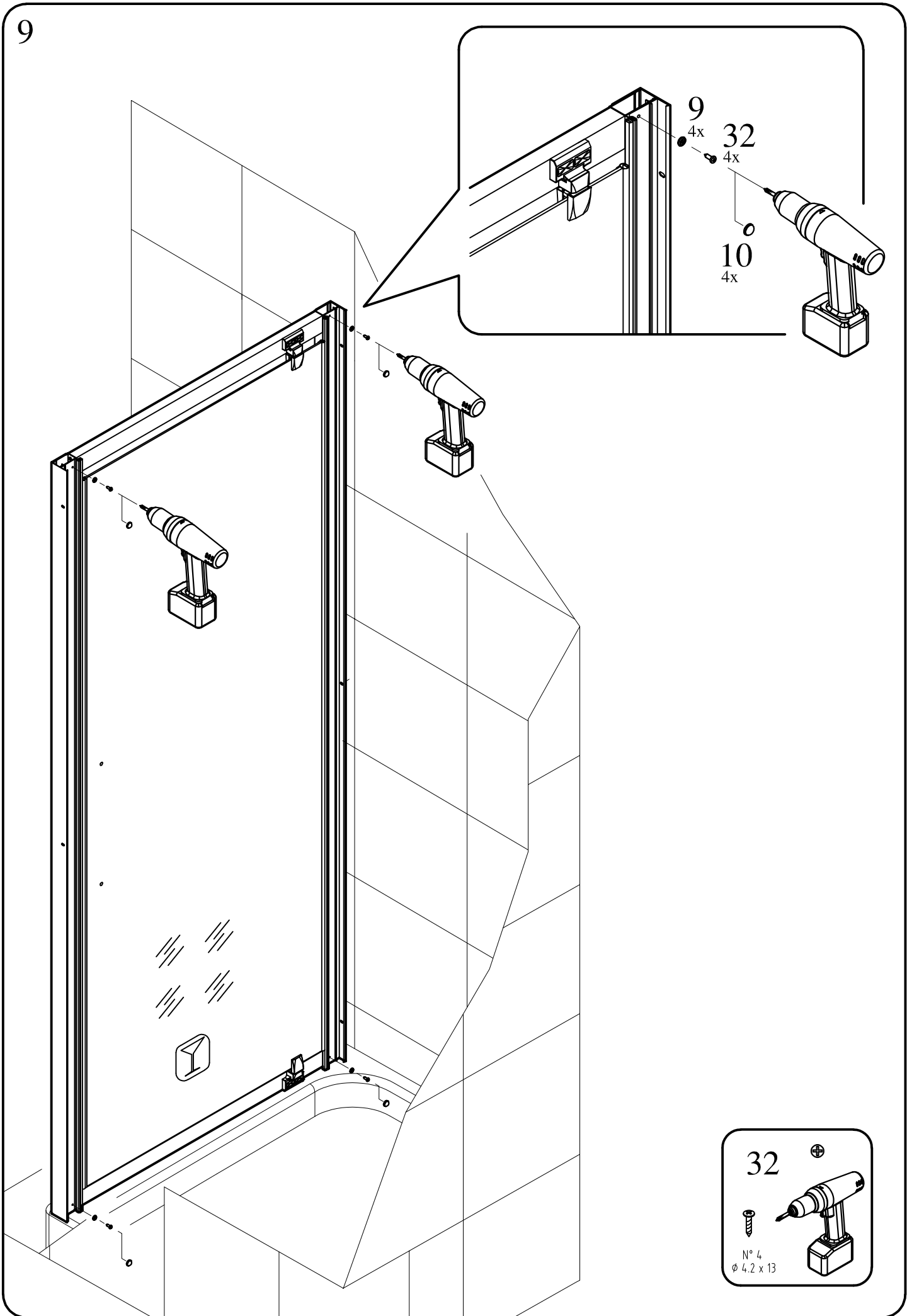

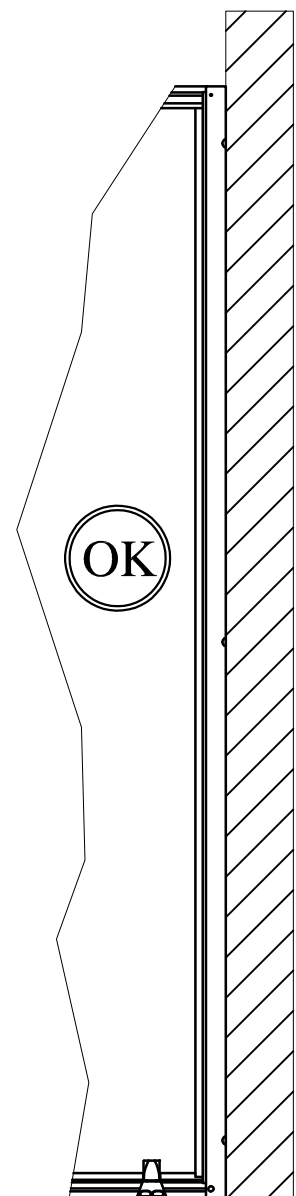
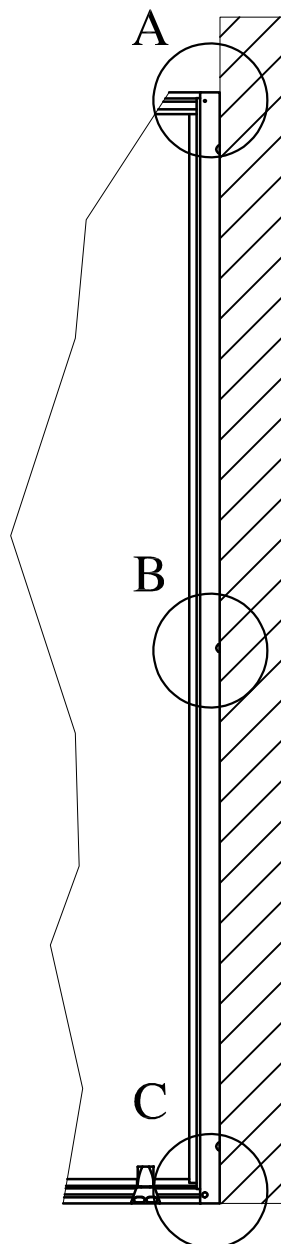
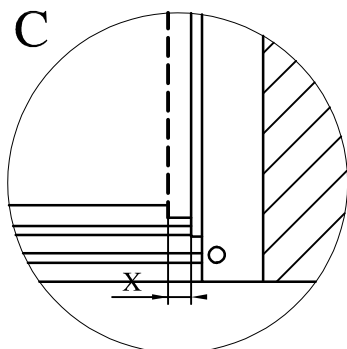
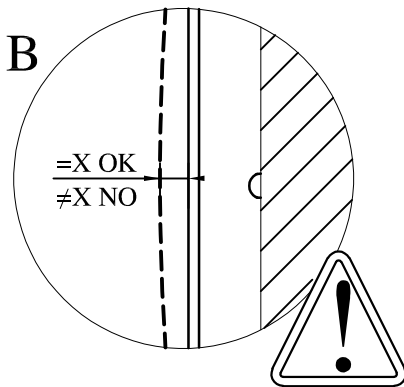
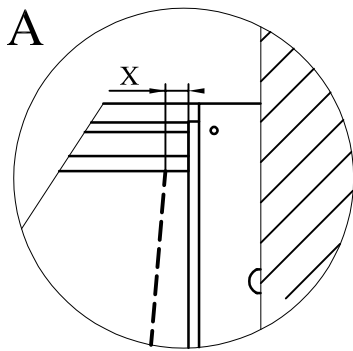
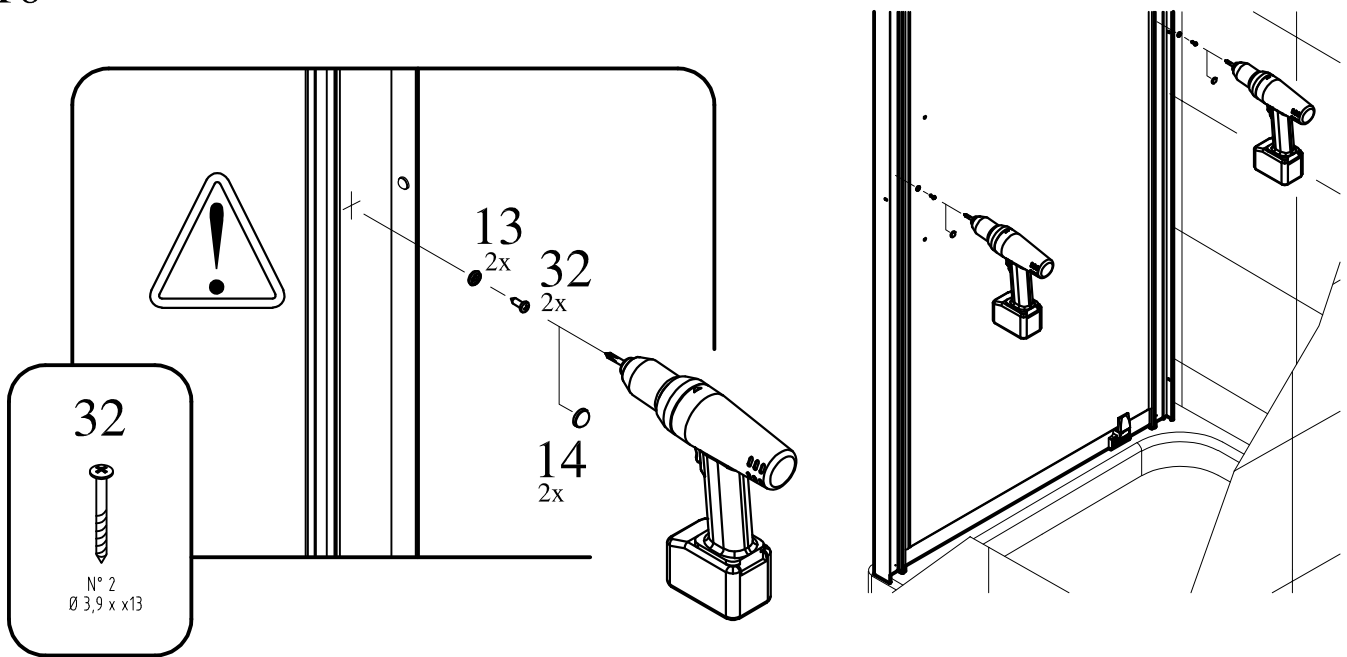

11

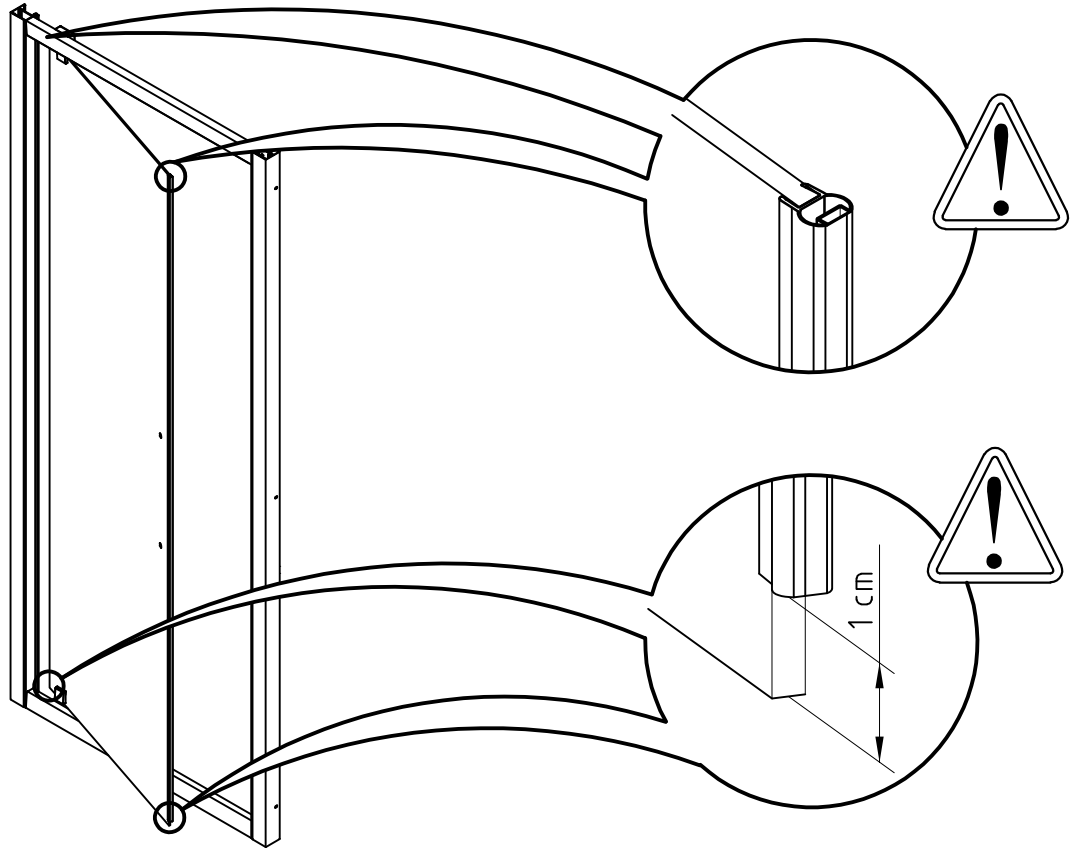

12

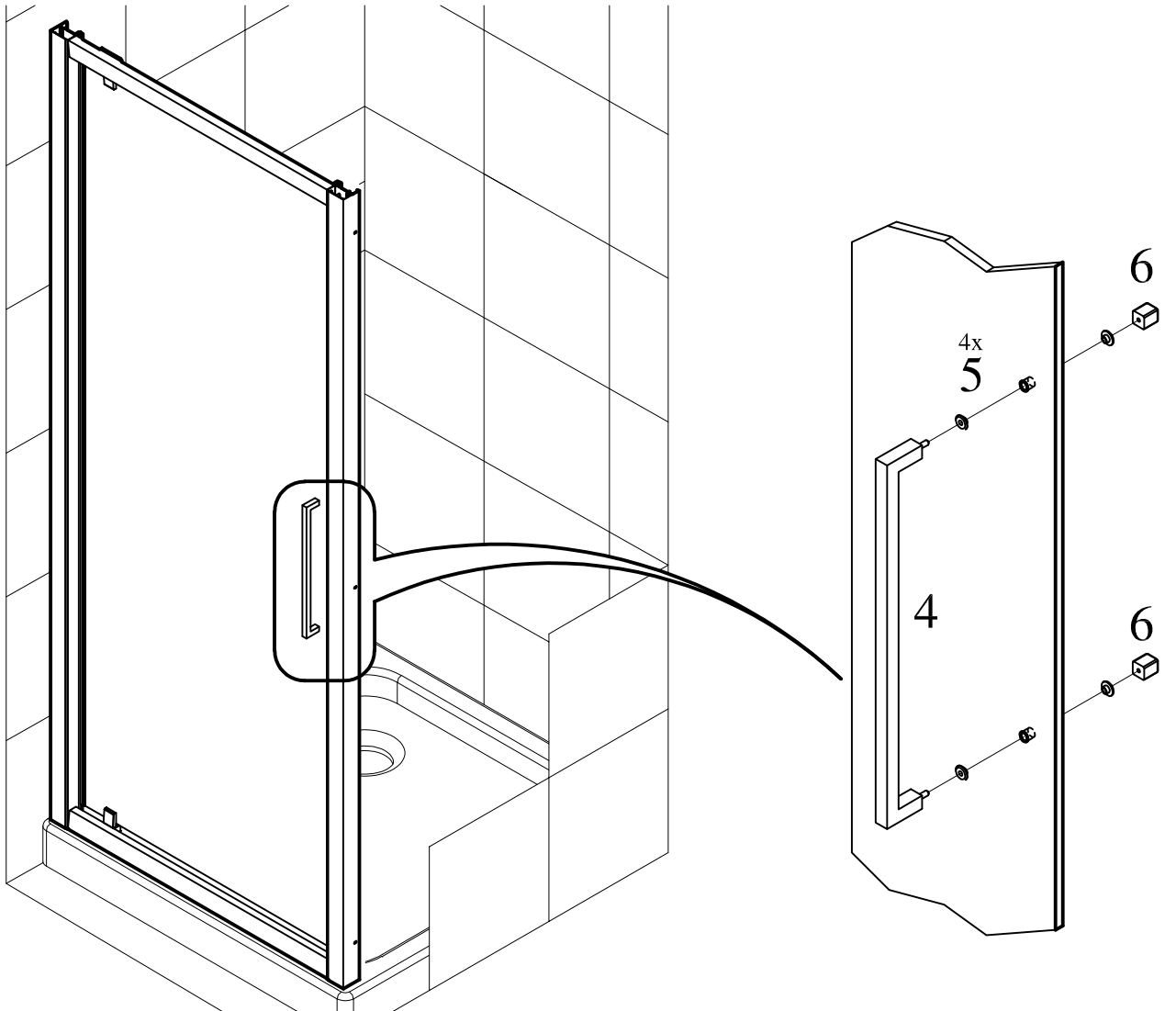



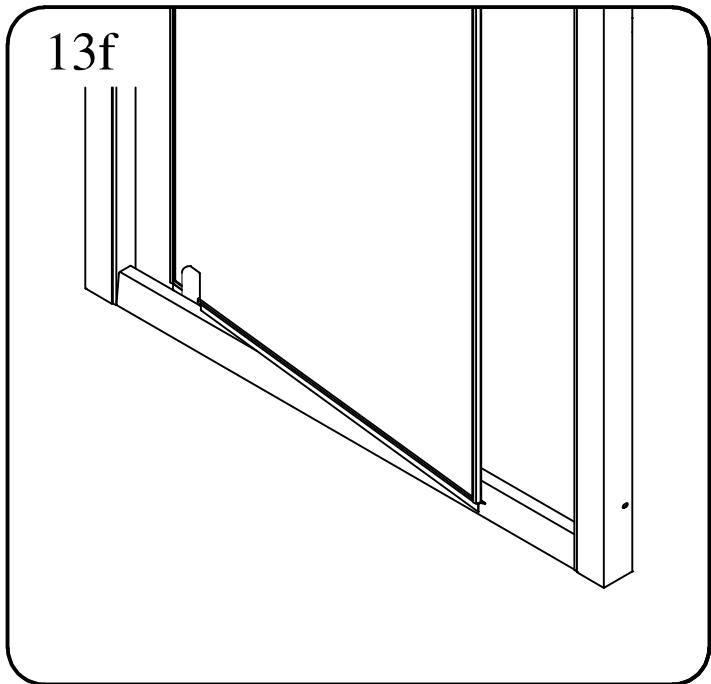
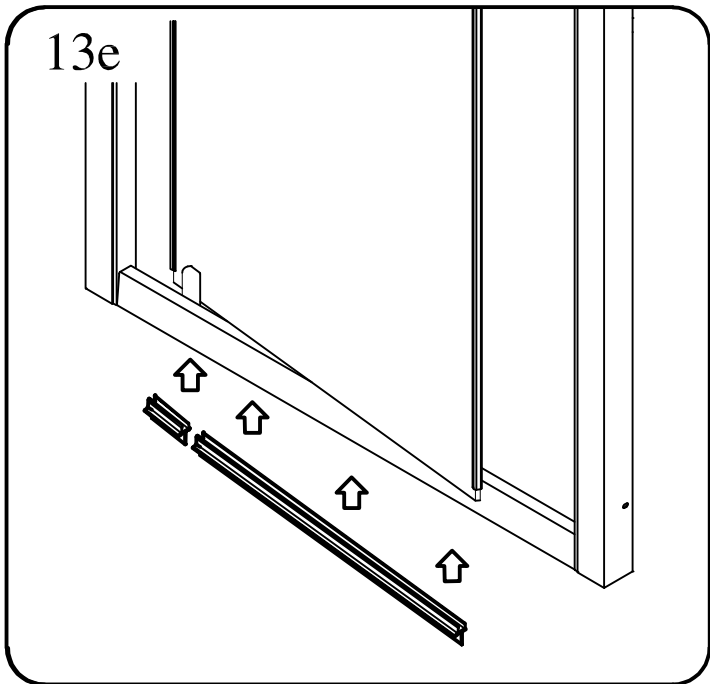
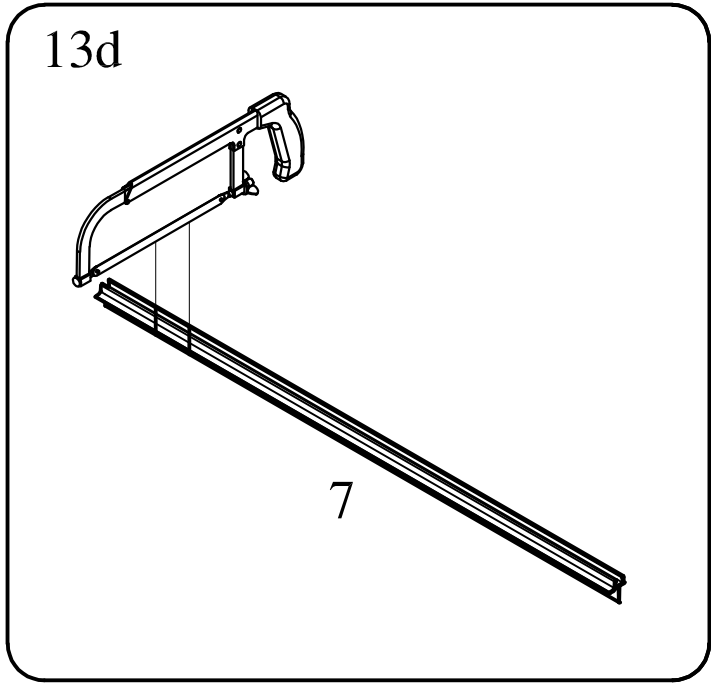
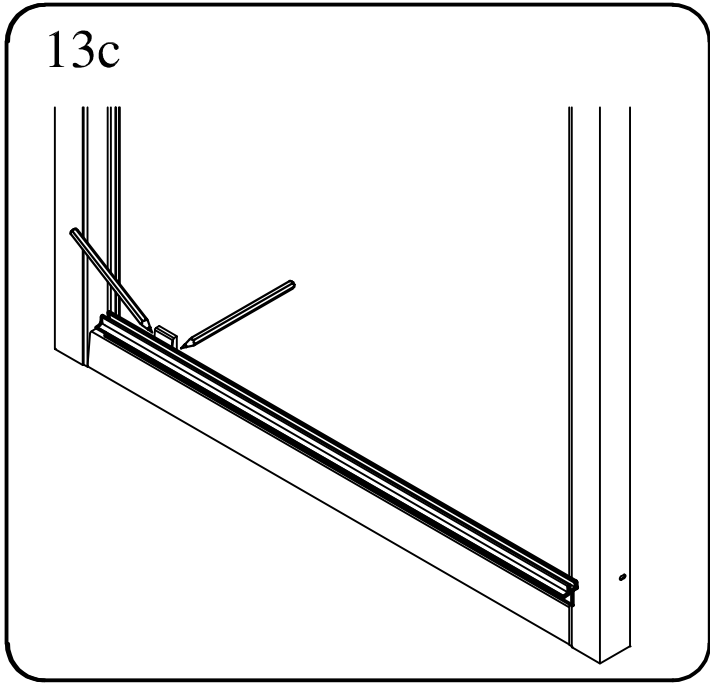
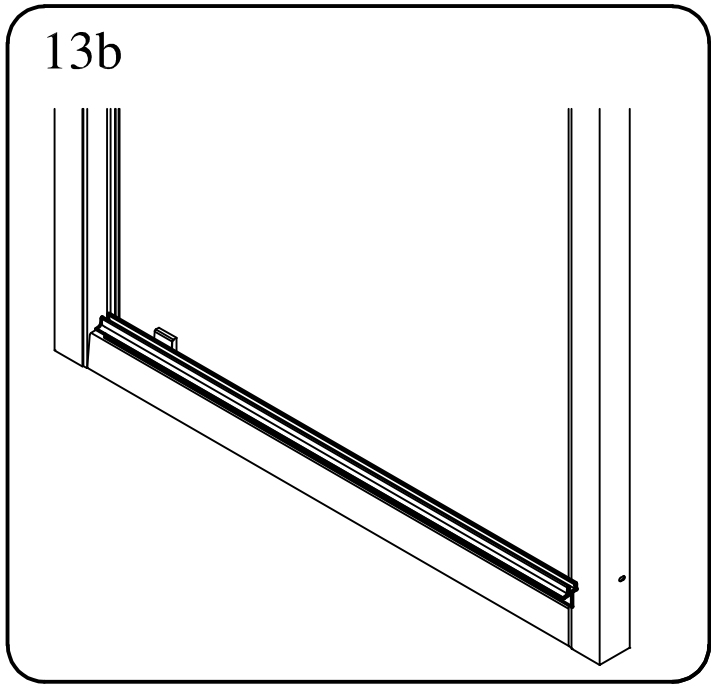
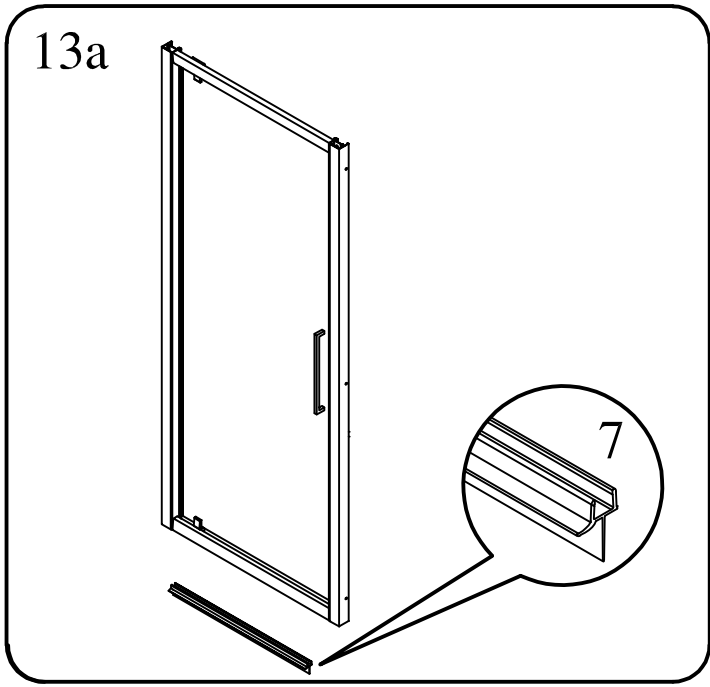

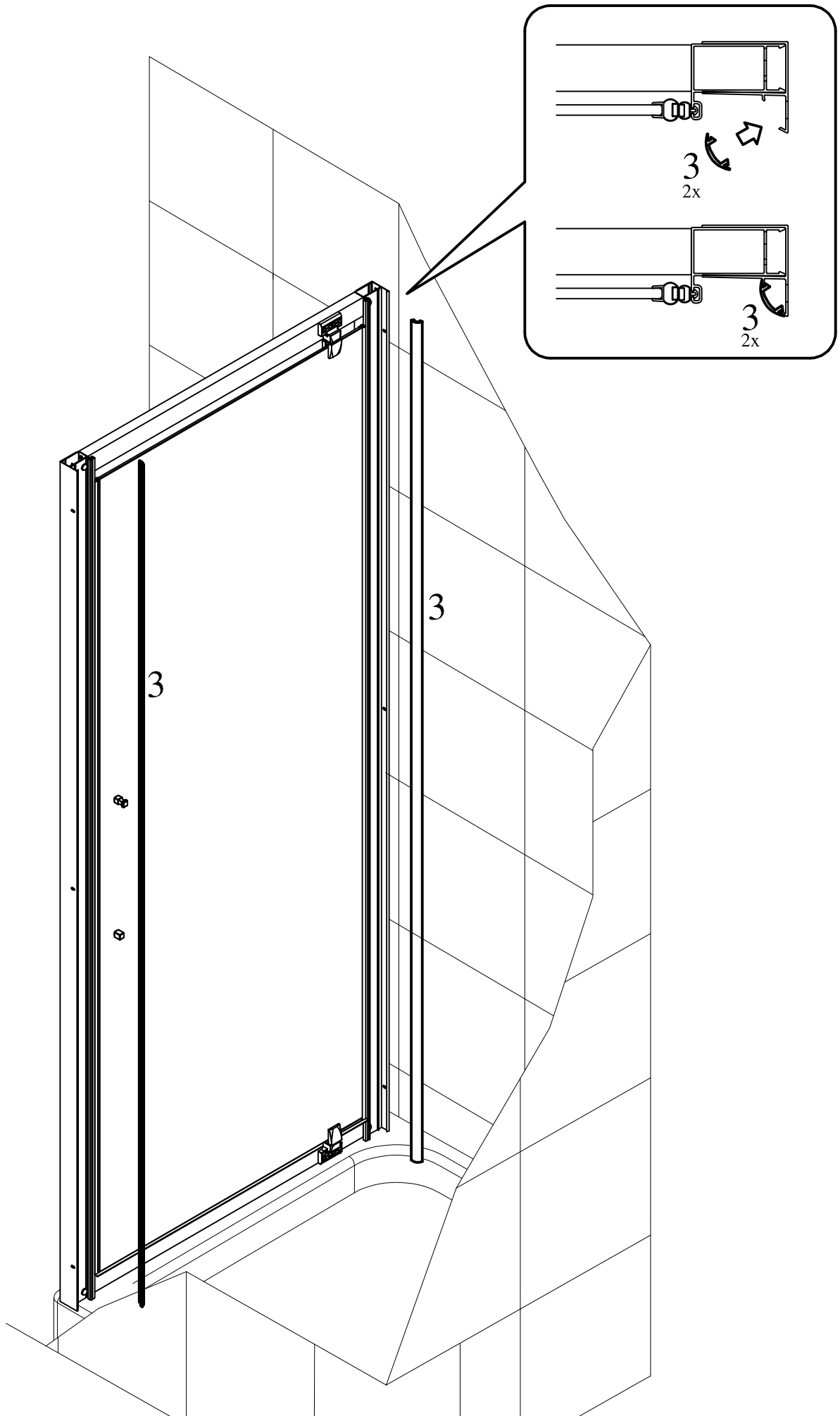

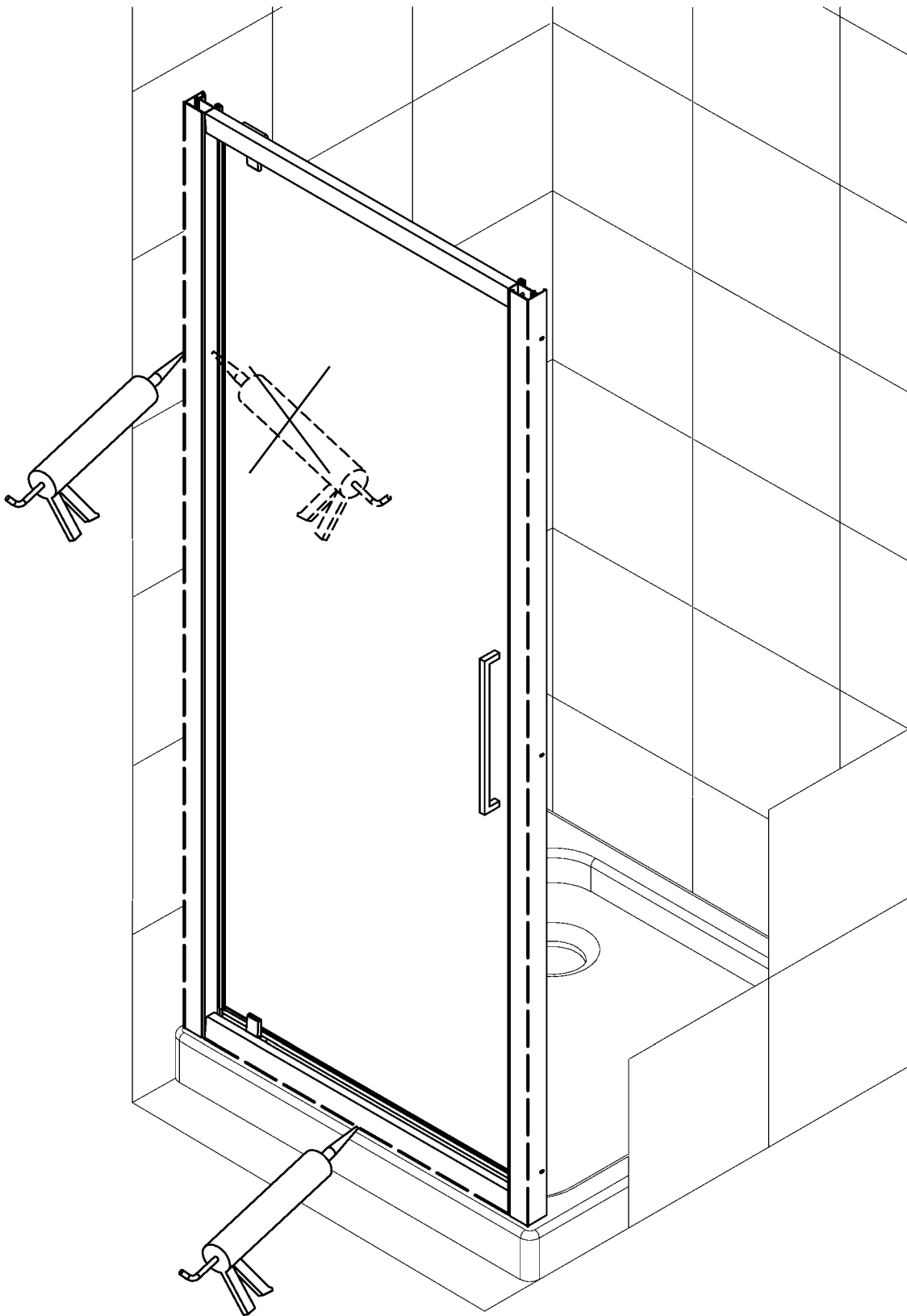

24 h

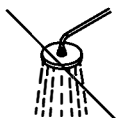

**SAMO SpA** - Via Cav. Orvile Venturato, 1 - 37040 Bonavigo (VR) Italy  
Tel. (+39) 0442 73018 - Fax (+39) 0442 670033  
[www.samo.it](http://www.samo.it) • [samo@samo.it](mailto:samo@samo.it)

**SAMO FRANCE S.a.r.l.** - 735, rue Georges Claude - Z.I. Les Milles - 13290 Aix-en-Provence  
Tel. +33 (0) 491 58 20 63 - Fax +33 (0) 491 635546  
[commercial@samofrance.fr](mailto:commercial@samofrance.fr)

